

## Building a 1:8 Scale Napier-Railton Race Car

### Introduction

From 1917 through the early 1930s, the Napier Lion Aero Engine was at the core of British aircraft developments. It was a twelve cylinder 'W' arrangement of three rows of four cylinders which, in its basic form developed over 450 HP. But in racing form it could deliver in excess of 1,300 HP. It was the most powerful engine of its day and was used in a number of racing designs, not just for aircraft but also for boats and cars.

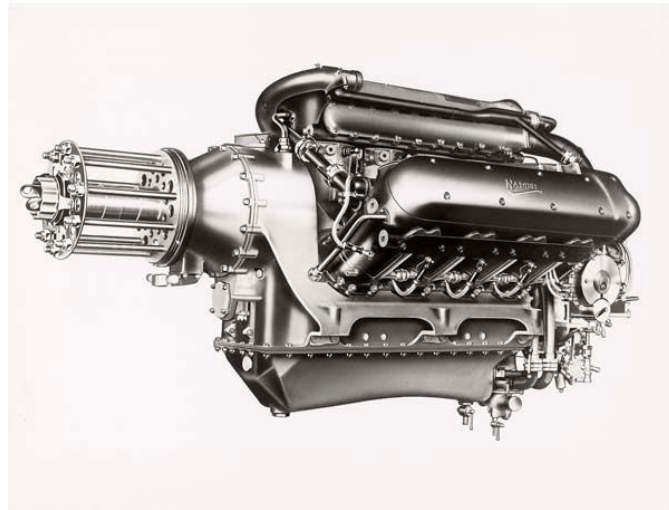

Napier Lion engines powered the two Supermarine S.5s which were Britain's 1927 entry in the very popular Schneider Trophy race for seaplanes and flying boats. The international race was flown around a fixed course and attracted large crowds. The two Supermarines came first and second. Over the next five years, there were two more races which Britain also won. Under the rules of the contest, that meant that Britain got to keep the trophy permanently.

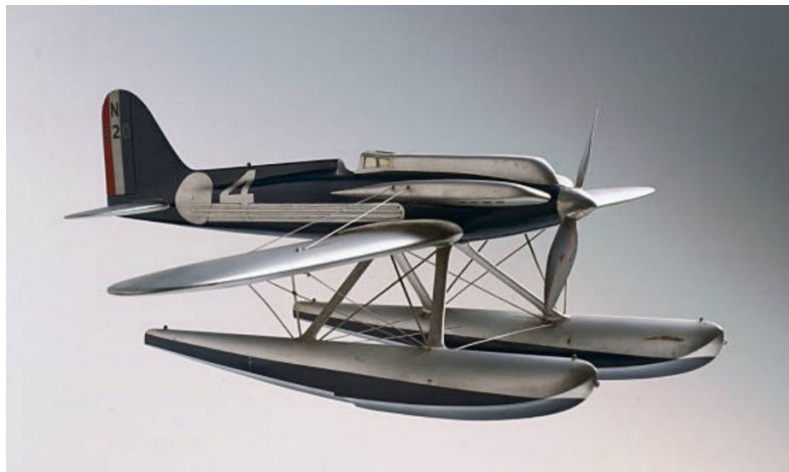

Napier Lion powered Supermarine S.5

The Supermarine S.5 really is a beautiful design and I have to think it contributed to the streamlined design thinking that really came into vogue in the 1930s.

In 1931 Malcolm Campbell set a new land speed record of 246 mph driving his Blue Bird car powered by a supercharged Napier Lion engine. For his efforts Malcolm Campbell was knighted.

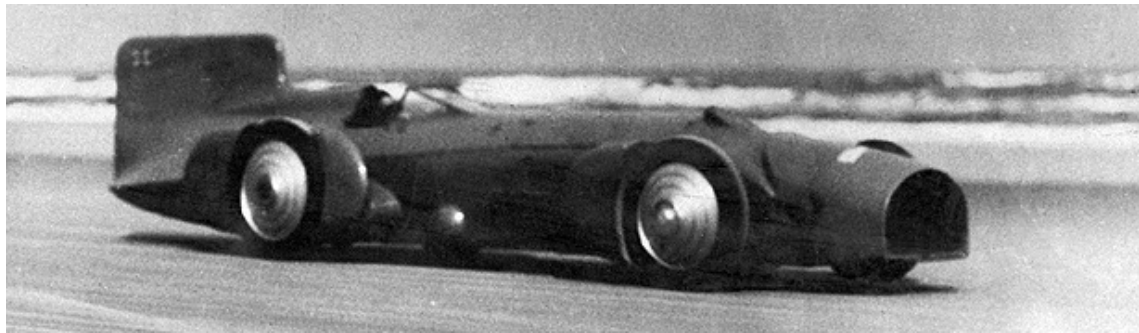

Blue Bird 1931

Between 1933 and 1935, John Cobb's Napier Lion engined Napier-Railton race car achieved a number of lap records at Brooklands, including a one lap record of 143 mph that was never beaten. The car also broke many endurance speed records.



Napier-Railton at Brooklands  
Top speed was almost 170 mph.

Both the Supermarine S.5 and the Napier-Railton race car seemed like excellent candidates for 1:8 scale models. Each would fit well with my suite of 1930s car models that showcased the transformation of transportation in the 1930s. The common denominator was, of course, the Napier Lion engine. So, if I could build a model of the engine then models of the Supermarine S.5 and the Napier-Railton might be possible. Of course, since the engine is enclosed by bodywork, it would always be possible to build models of the plane and of the car without modeling the engine. But my interest is in building a 1:8 scale replicas rather than just representational models.

However, to complicate things, the engine could be built in several different configurations. The version for the Supermarine S.5 dispensed with the large gear reducer and housing on the front of the engine and opted, instead, for a direct drive off the crankshaft. That, together with shorter con rods and lower camshafts, helped lower the profile. The Napier-Railton race car also used direct drive, but the housing for the large gear reducer was kept and simply blanked off. There were other differences too in the type of magneto used, the type of carburetor used and where they were located.

## Starting Point

As with almost all scratch-built models, the starting point is getting or creating a set of drawings. But drawings from the early part of the 20<sup>th</sup> century aren't easy to find and the Napier Lion engine was no exception. Eventually, however, I was able to find an instruction book that included basic drawings of the engine. They were enough to get started.

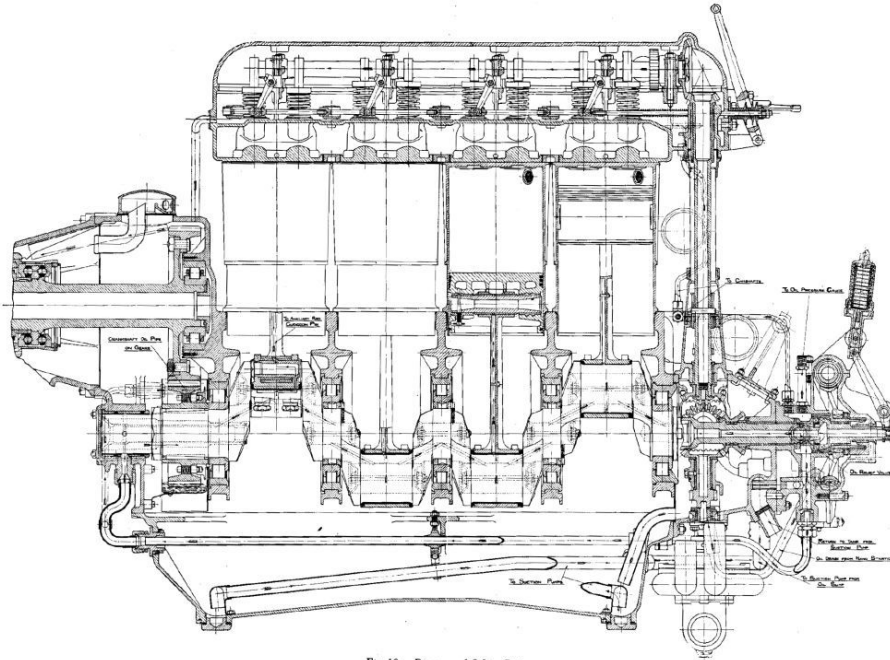

Fig. 10.—Diagram of Oiling System.

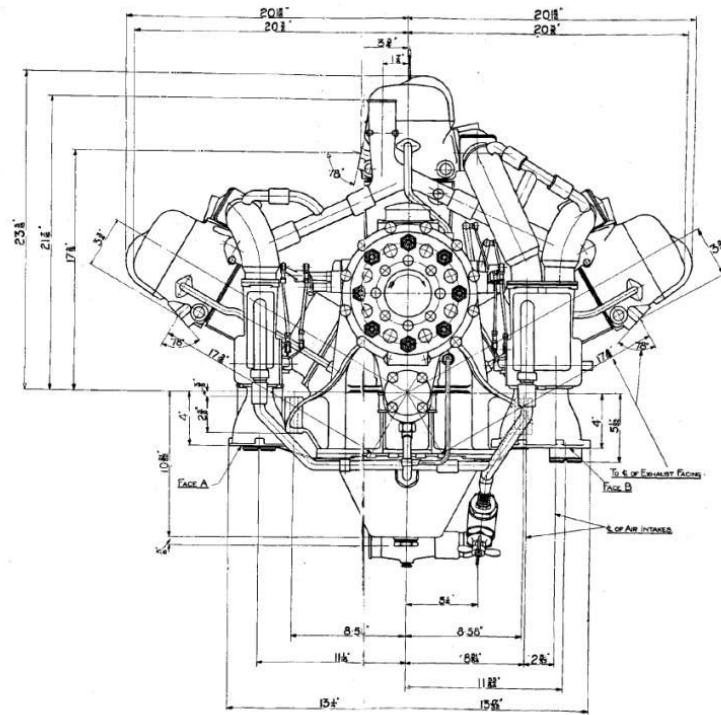
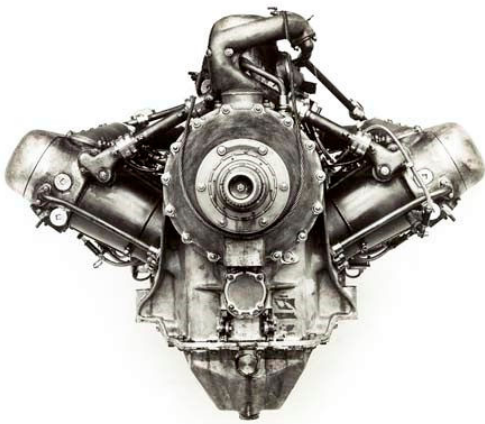
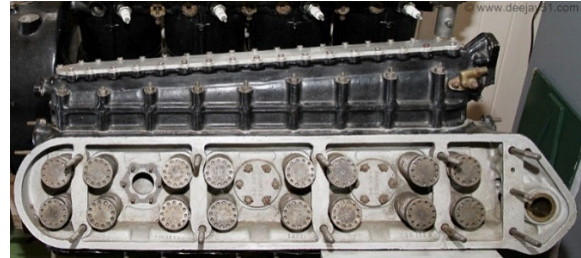
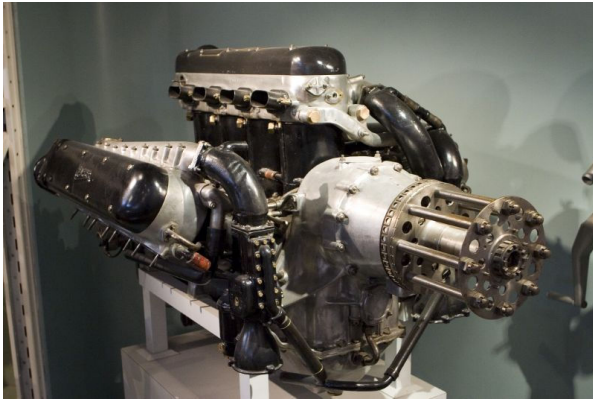

Fig. 27.—Front Elevation—Tractor Type.

Fortunately, it was easier to find photographs of the engine and some of its critical components. They would be crucial in helping convert the 2D drawings into 3D CAD drawings and renderings. The challenge would be matching the various photos with the different versions of the Lion engine. Once the CAD drawings had been created, my goal was to 3D print the critical parts.

## Photographs

Here are just a few of the photographs I found:



Different photographs and drawings show several configurations for the Lion engine; e.g. offset drive vs. direct drive, carburetors at front or rear, magnetos at front or rear. In the traditional aircraft arrangement a large reduction gearbox was mounted on the front of the engine. This moved the centerline of the propeller approximately 8" above the crankshaft. This is the arrangement shown in the cross-section drawings I found. However, both the Supermarine S.5 and the Napier-Railton race car used a direct drive arrangement where the power was taken off directly in line with the crankshaft. Here are some more pertinent photographs, the first showing the Lion engine being installed in the S.5;

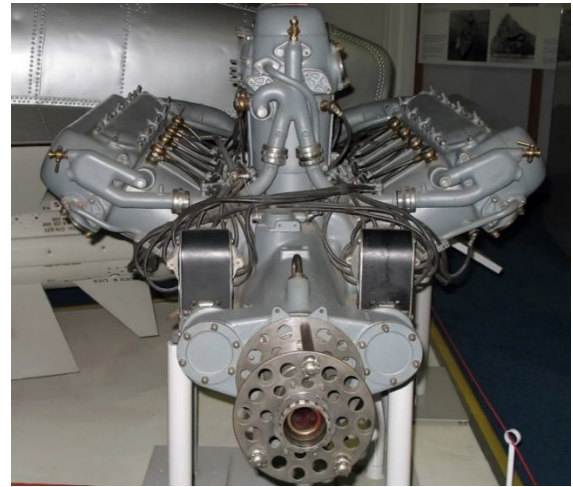
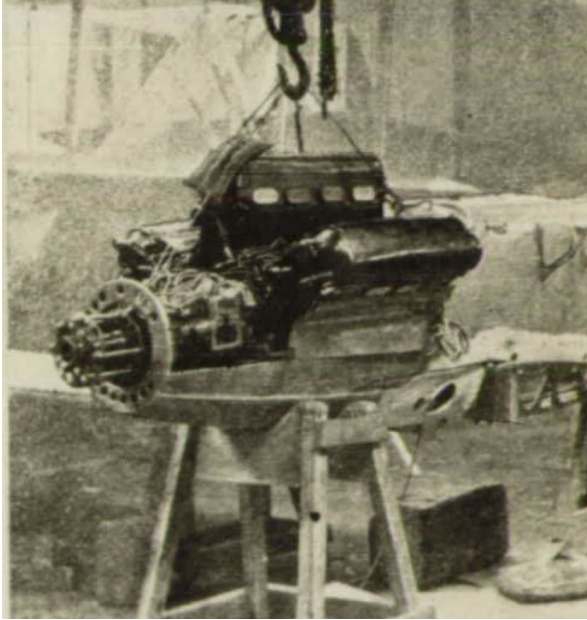

And here's a sketch of the Napier-Railton racecar chassis. Although it featured direct drive, the distinctive housing for the large gear reducer, commonly used in aircraft applications, is clearly visible even though it wasn't used.

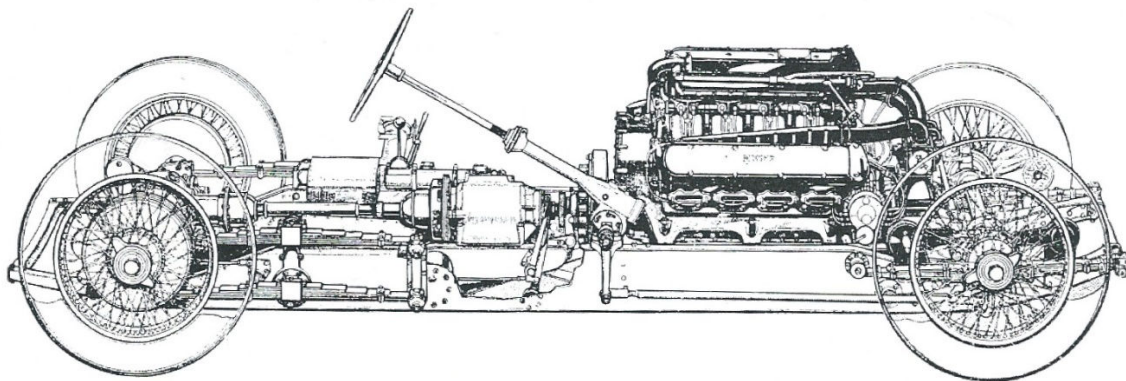

The carburetors and magnetos are mounted on the rear of the engine (i.e. the front of the car). This version is the Lion XIA.

Below is a history of the various versions of the Lion engine:

NAPIER LION VARIANTS													
Model	Date	Desig.	Power BHP	At RPM	Drive Type	Magnetos	Carbs	Exhaust	Takeoff	Cam Drive	Notes	Notable uses	
								Left	Conr	Right	Left	Conr	Right
I	1918	E64	450	1,950							I	E	I
II	1919	E64	480	2,200	Reducer	Rear	Front	L	R	R	I	E	I
III		experimental geared			Reducer	Rear	Front	L	R	R	I	E	I
V			470 500	2,000 2,250							VA had increased CR to 5.8	Mainstay engine of RAF in the late 1920s, replaced by Lion XI	
VS		E79									Turbocharged, intercooled		
VIS	1927										Turbocharged	<a href="#">Gloster Guan</a>	
VII	1925		700 (racing)		Direct	Front	Rear	L	L	R	E	E	E
VIIA	1927	E86	898 (racing)		Direct	Front	Rear	L	L	R	E	E	E
VIIIB	1927	E90	875 (racing)		In-line 'coaxial' reducer	Front	Rear	L	L	R	E	E	E
VIID	1929	E91	1,350 (racing)	3,600	Direct	?	Rear	L	R	R			
VIII	1927										Direct drive	<a href="#">Gloster Gorcock</a>	
XIA	1928		580 (6:1 CR)	2,585	Direct Rdcr Fairng	Rear	Rear	L	R	R	E	I	E
Lioness		E71									Inverted layout, for better visibility. At least some were built turbocharged, for racing.		
Sea Lion	1933		500 & 600								Marine version of Lion XI	<a href="#">British Power Boat Company Type Two 63 ft HSL</a>	
								L = Left		E = Exhaust Side			
								R = Right		I = Inlet Side			

Originally, I thought (hoped) that the differences between the engine used for the 1927 Schneider race and the engine used for the Napier-Railton race car would be relatively minor. Instead, it is clear from the above that the differences would be substantial. In reality, drawings for two separate engines would be required and two different sets of 3D printed parts.

Given that, I decided to focus first on the XIA engine of the Napier-Railton.

## Renderings

At every step, the goal was to produce drawings from which parts could be 3D printed. That is what you will see in all of the renderings. My CAD skills are somewhat limited, (I use it only for hobby work, after all) but I felt they were adequate enough for this project. Purists and experts will likely find lots of places for improvement. I wouldn't argue with their assessment!

To give you an idea of the scope of the project, the following two renderings show the completed engine drawings. All the pieces shown are designed for 3D printing. The first rendering has the same aspect as that of the Napier-Railton chassis drawing.

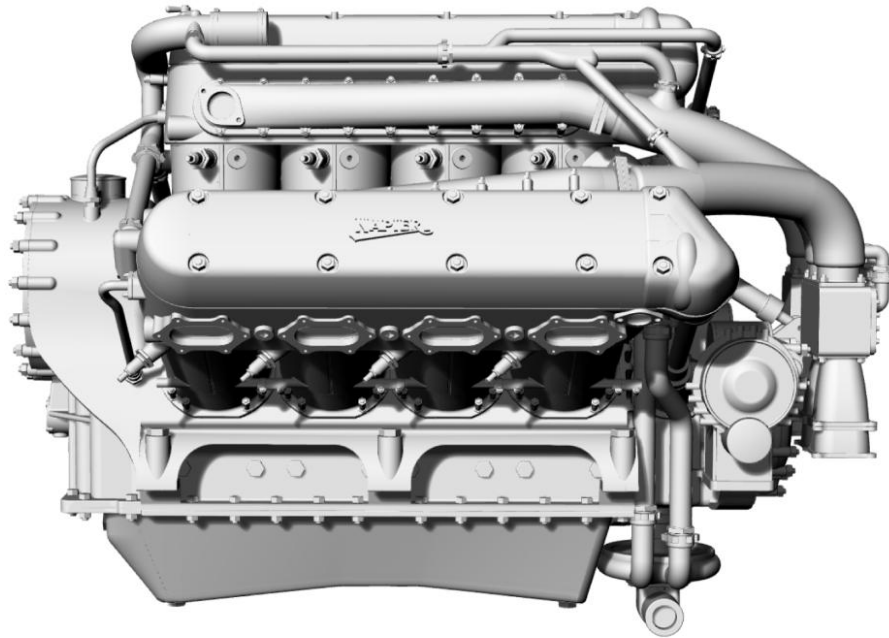

And this is a front three-quarter view ...

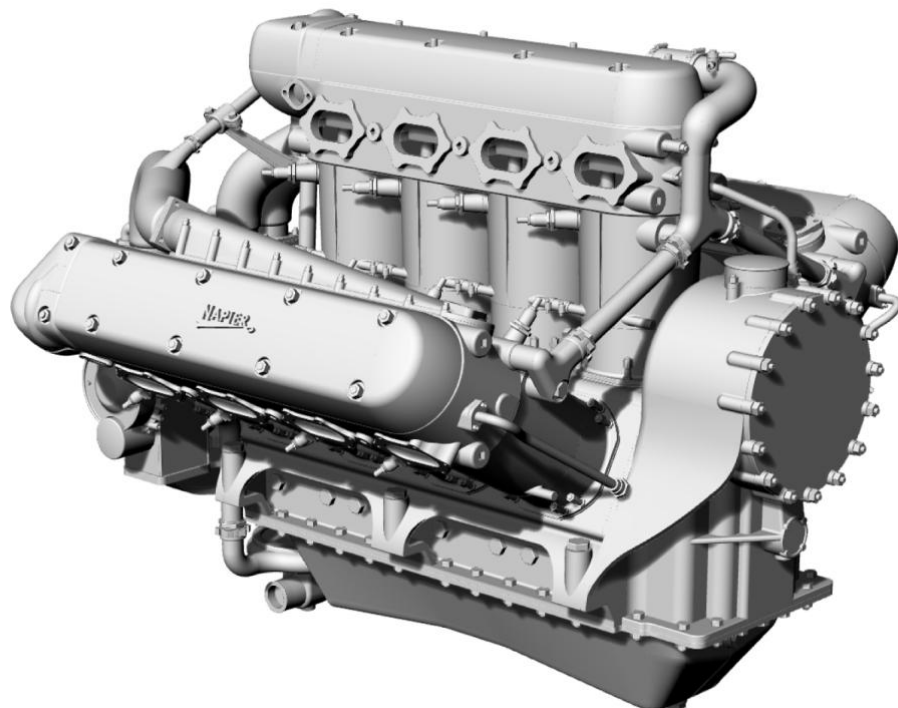

## Crankcase & Cylinders

My starting point was the crankcase and the cylinder blocks with their distinctive 'W' arrangement. Everything hung off the crankcase.

This picture is a rear three-quarter view. Visible through the holes for the cylinders are the upper supports for the crankshaft bearings. Although the internal parts of the engine would be hidden on the model, I wanted the model design to allow for crankshaft, connecting rods, pistons, and a full set of camshafts and valve gear.

The cylinders are water-jacketed. Also, water was used to heat the air passing through the carburetors and inlet manifolds. As you can imagine, and will see later, the water piping gets quite complicated

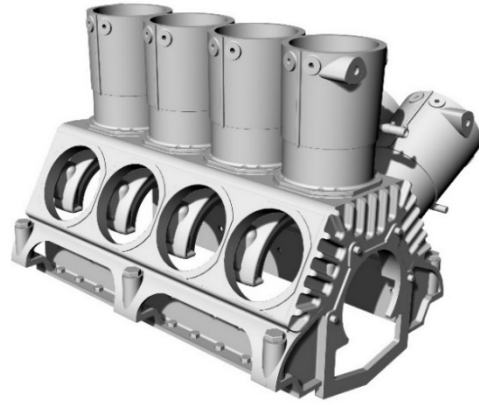

Each of the twelve cylinders had two spark plugs, arranged on opposite sides of the cylinder. They were fired by two separate magnetos.

This three-quarter right hand side front view shows the spark plugs and the water connections between the cylinders. Also, very prominent, is the gear reduction housing and the distinctive aprons that anchor the housing to the crankcase. The direct drive takeoff comes out through the large boss underneath the gear reduction housing.

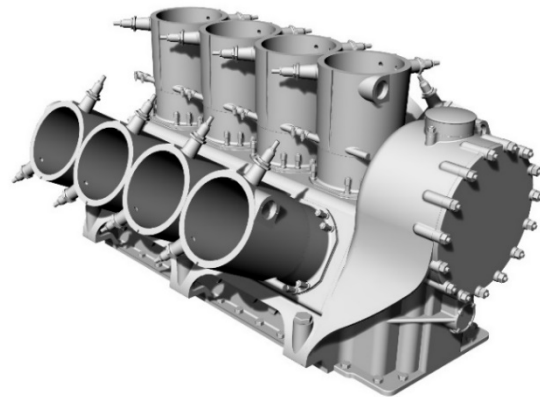

On prototype engines, the gear reducer housing and crankshaft were made from one large casting. However, for the model the two were separated to make 3D printing easier.

A view from underneath showing the lower crankshaft bearing supports. On the model, the lower supports are removable and will be bolted into place.

Although the crankshaft, connecting rods and pistons have yet to be drawn, it will be no problem to add them to the model. The three large bolts low on the side of the crankcase (and three additional bolts on the other side) mount the engine to its frame.

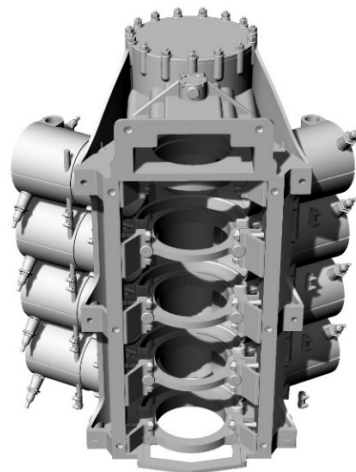



## Sump

Here the sump has been added. This creates the core of the engine.

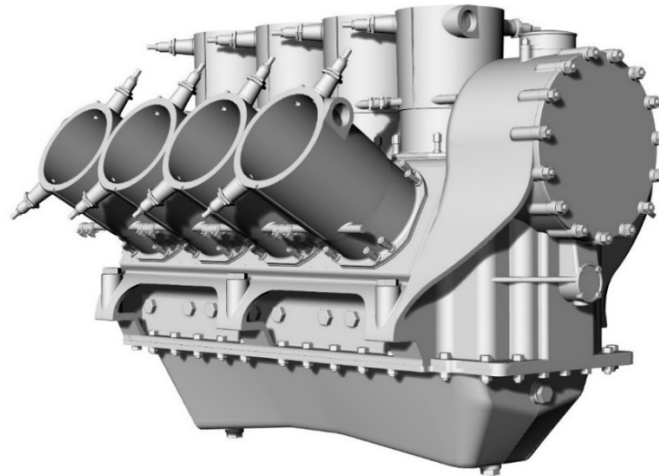

## Camshaft Drives

The next challenge was to create the cylinder heads, one for each bank of cylinders. Each cylinder head housed two overhead camshafts which operated two inlet and two exhaust valves per cylinder. The camshafts were gear driven through a drive box mounted on the rear of the engine. Shafts connected the drive box to the cylinder heads. So, the drive box was the place to start.

One of the benefits of a CAD-based model is that the interfaces between the various parts can be tested before parts are produced. This was going to be particularly important for the Lion model since the engine is such a compact design. Obviously, the location of the drive shafts would dictate the final dimensions of the rear of the cylinder heads

Here the drive box has been added ... mounted to the flange on the rear of the crankcase.

On the rear of the drive box are the platforms for the magnetos, one on each side of the engine. Also visible on the platforms are the pegs that will help properly locate the magnetos when mounted to the model.

The camshaft drive shafts align directly with one of the camshafts and, as you can see in the right-hand photo, they are skewed off the centerline of the cylinders, just like on the prototypes.

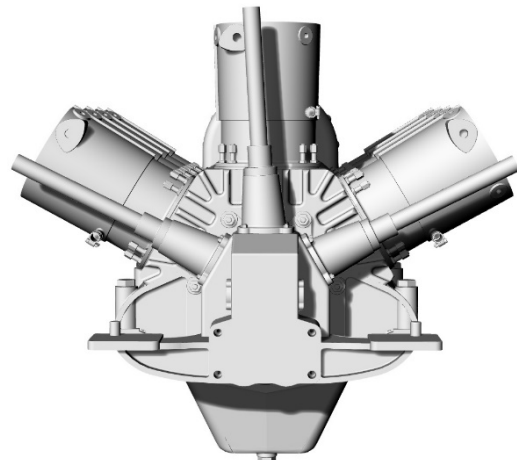
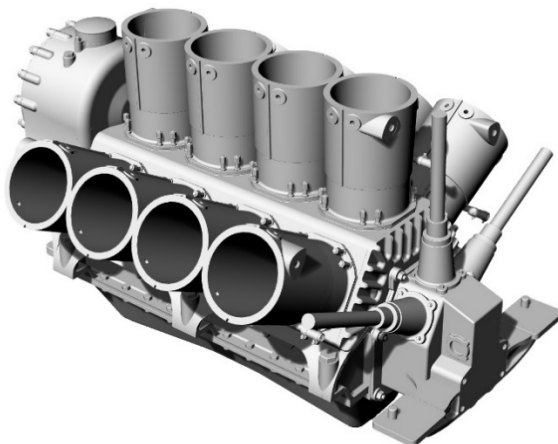

## Cylinder Heads

Here are details of the left-hand side cylinder head showing the complexity of design that 3D printing can produce. In 1:8 scale the cylinder head is approximately 100mm long and 20mm wide.

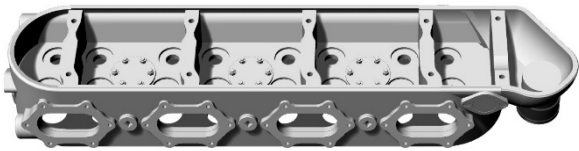

This side of the cylinder head shows the exhaust ports.

The cross pieces are the platforms for the camshaft support blocks.

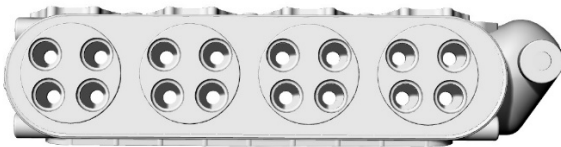

Here the four-valve arrangement is very clear.



This is the inlet side. The opening to the inlet valves would normally run the length of the cylinder head, but you can see that I've made provision for two large pegs to hold the inlet manifold in place.

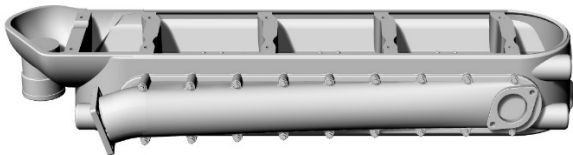

Here the inlet manifold has been added

This is the engine block with all of the three cylinder heads and inlet manifolds:

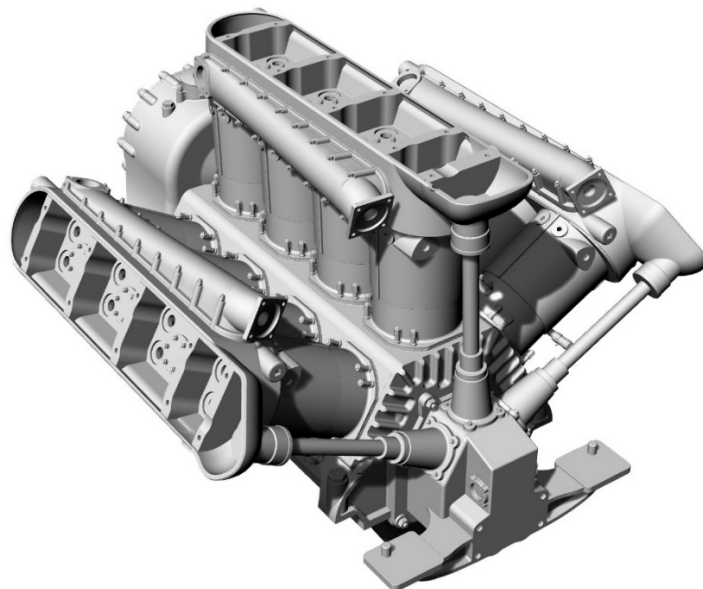

## Camshaft & Valves

With the overall cylinder head dimensions and shapes established, the camshafts and valves could be added:

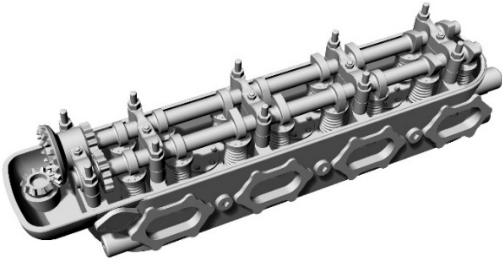

In order to meet 3D printing limitations, the pitch of the gears on the model had to be made significantly bigger than on the prototypes. But the arrangement is the same.

Long studs pass through the camshaft support blocks and anchor the supports in place. Those same studs also pass through the camcase covers to hold the covers down onto the cylinder heads.

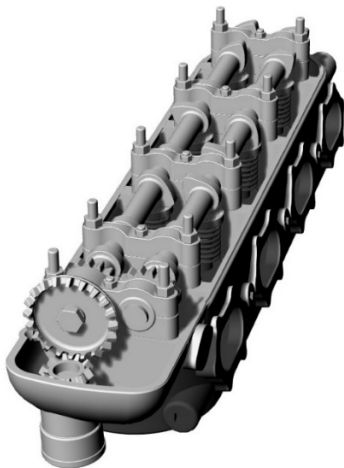

The lobes on the camshaft were set based on the firing order and the typical sequence of a four -stroke engine cycle.

On the Lion engine, the cylinder numbering, from the front of the engine, was:

Left: 12, 11, 10, 9

Center: 5, 6, 7, 8

Right: 4, 3, 2, 1

And the firing order was:

1, 5, 9, 3, 7, 11, 4, 8, 12, 2, 6, 10

It gets a bit complicated because the inlet and exhaust camshafts counter-rotate and the exhaust ports are on the left of the left cylinder bank and on the right of the center and right banks. So, I treated each camshaft as unique and had them 3D printed accordingly. Does it really matter? Probably not, but why not try to get it right?

There are two valve springs for each valve, one inside the other. A valve cap sits on top of the springs and is attached to the top of the valve stem. A ratchet system lets the length of the valve assembly be adjusted by rotating the cap relative to the stem. The cam lobe impinges on the top of the cap.

The springs will be hand made from wire, but the valve, stem and cap will be 3D printed.



Prototype Valve

Here's a rendering showing the engine with its cylinder head and a prototype engine. Note that, in contrast to the model, the prototype has inlet manifolds oriented for front mounted carburetors.

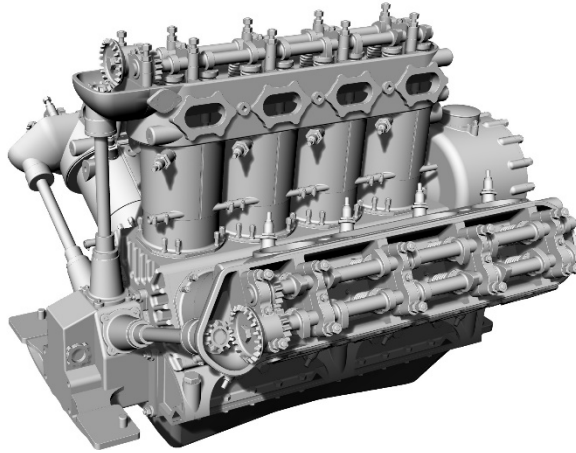

### Camcase Covers

Drawing the camcase covers was relatively straightforward except for the rears where the covers are bulged to accommodate the large camshaft gears. Care also had to be taken to make sure the covers cleared the camshaft supports.

The first photo below shows the left-hand side and center camcase covers installed on their respective cylinder heads. The second photo shows the overall progress with the drawings.

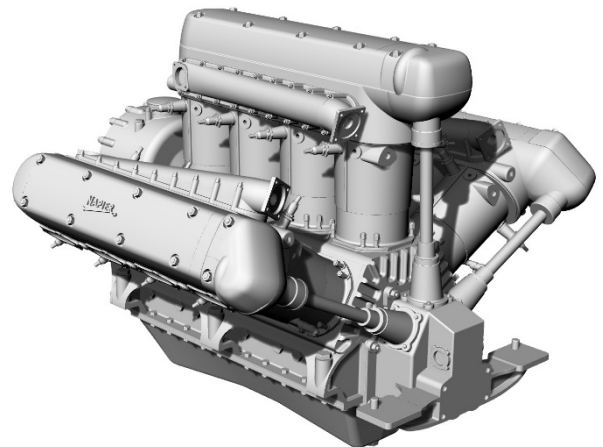

## Magnetos

As mentioned before, the magnetos were mounted on platforms extending out from the sides of the camshaft drives housing. Each magneto fired twelve spark plugs. The Magneto design was fairly consistent and dimensions were readily available from the various drawings.

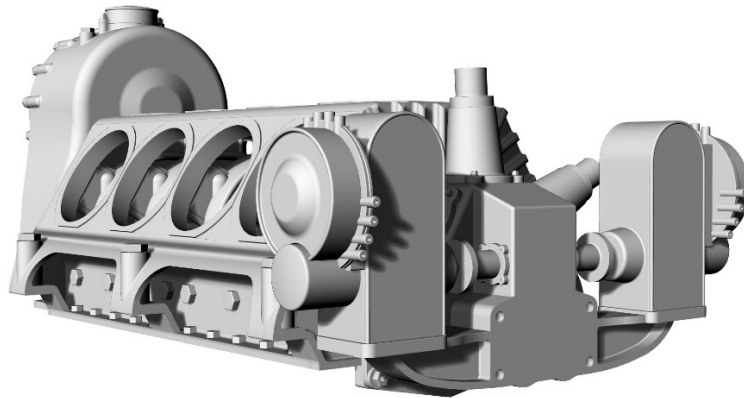

## Water Pump

The water pump was mounted on the underside of the camshaft drives housing. Three pipes led from the centrifugal pump to each cylinder bank as shown by this rendering:

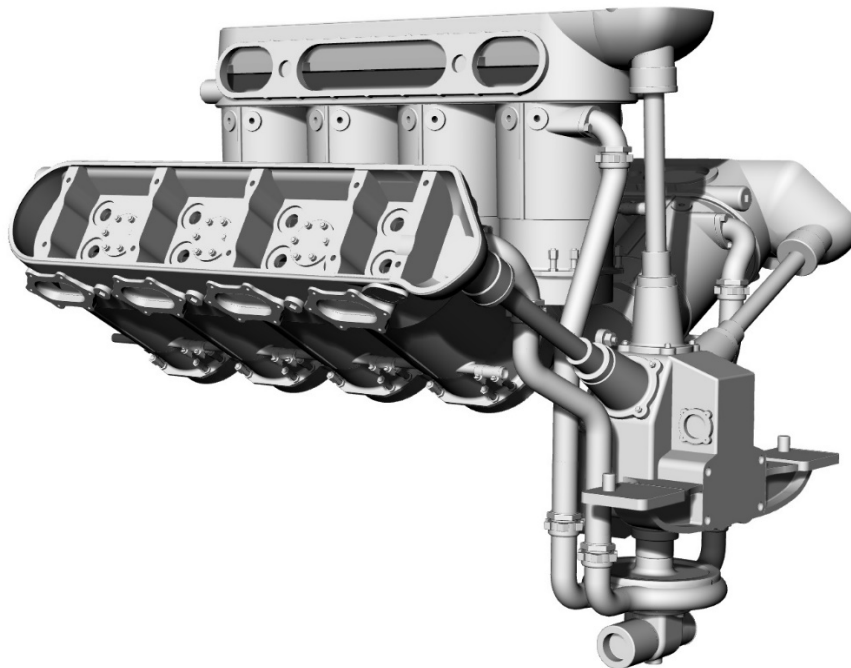

You can see from this rendering how compact and complex the rear of the engine is becoming.

## Oil Pump & Oil Lines

The oil pump was attached to the rear of camshaft drives housing. It also provided support for the carburetors. You can see the air intakes and carburetor platforms on the right of the photo.

The large 'L' shaped bracket above the carburetor platforms is for a lever that is part of the hand start mechanism.

Oil lines at the front of the engine drain oil from each cylinder head into the crankcase, as shown below:

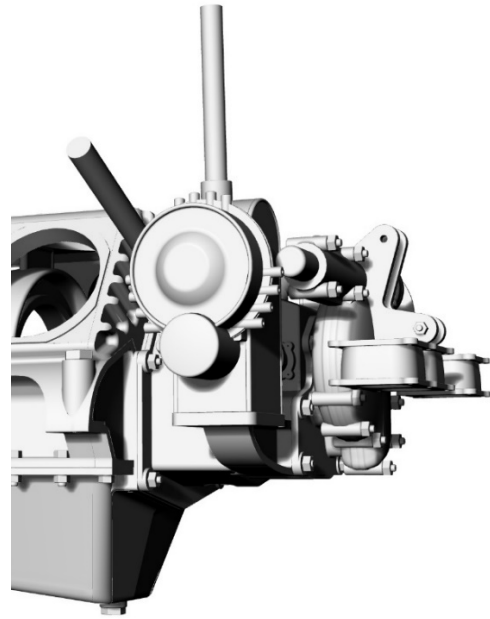
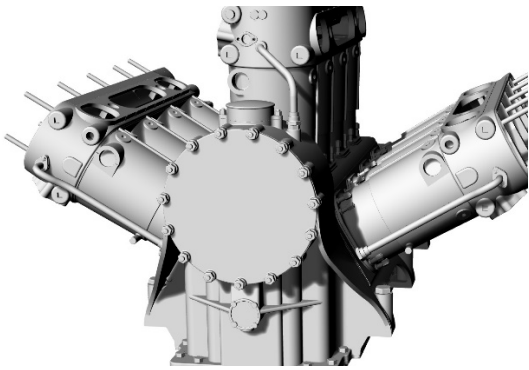

## Carburetors & Inlet Tubes

The last major components to add were the carburetors and the water-heated inlet tubes that connected the carburetors to the inlet manifolds. Each of the three banks of four cylinders had its own carburetor. The two on the left were combined into what was called a duplex arrangement and the one on the right into a simplex arrangement. The carburetor design changed significantly during the period the Lion engine was in production and it appeared that the Napier-Railton used a later version of the carburetors. So that's what I chose to use for the model.

Air flowed up through the carburetors and then the combined air/fuel mixture was fed to the inlet manifolds through water-jacketed tubes. Hot water from the return pipe was used to heat these tubes.

Here's a rear three-quarter view showing the carburetors and inlet tubes.

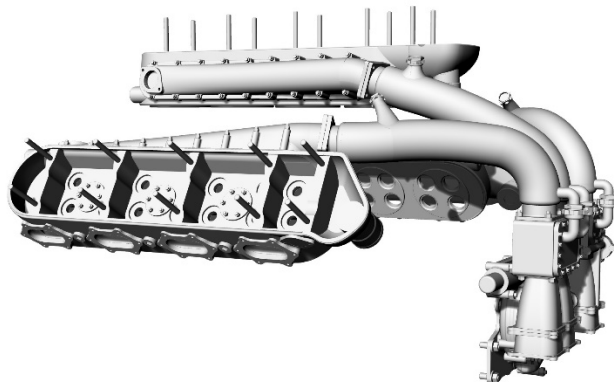

Here is more detail of the carburetors:

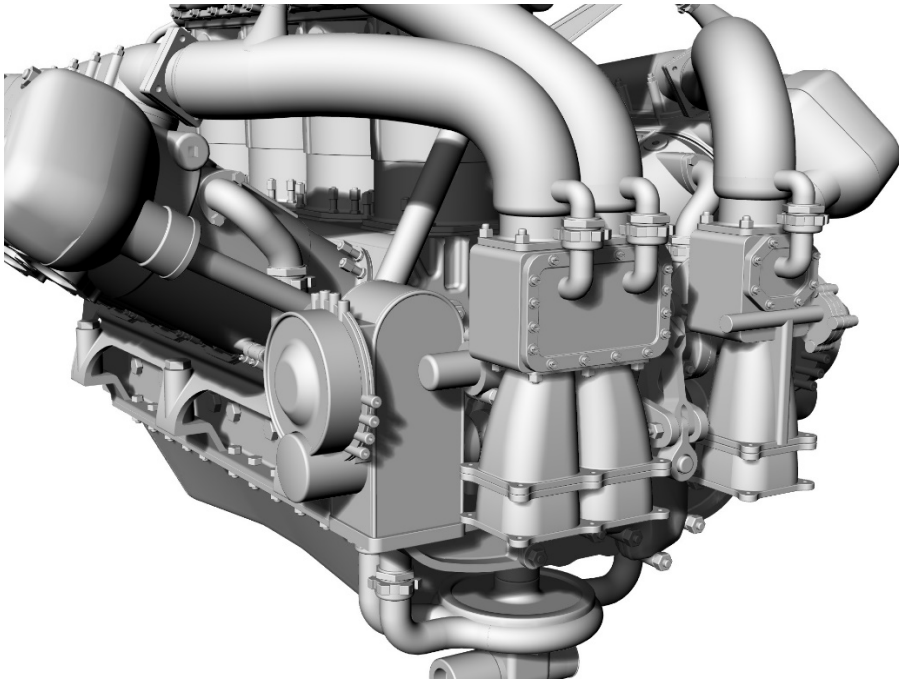

And, here, more detail of the water lines to the inlet tubes:

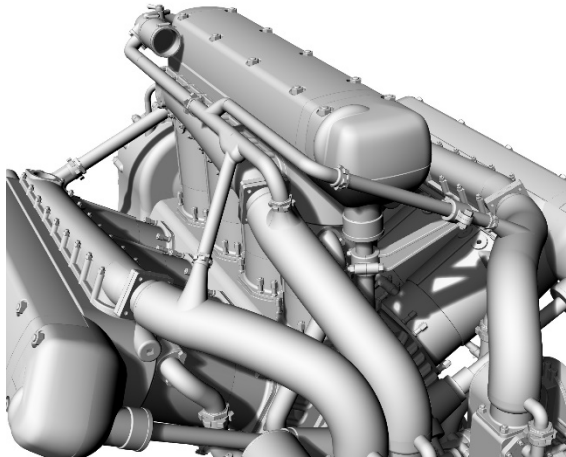
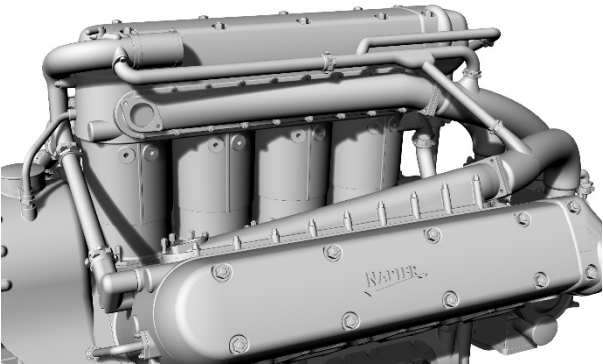

## Crankshaft & Pistons

Waiting for the 3D printed parts to arrive was an opportunity to draft up the crankshaft, connecting rods and pistons. They would add an interesting 'working' element to the engine.

The crankshaft was relatively straightforward, except for the lands on the crankshaft between the con rods and the main bearings. As you'll see later, the main bearings have to pass over these lands when they are installed, so it was important to dimension them carefully.

Here's the crankshaft, based on Napier Lion dimensions. The end shafts will need some more work before 3D printing is started but, otherwise, the crankshaft is complete:

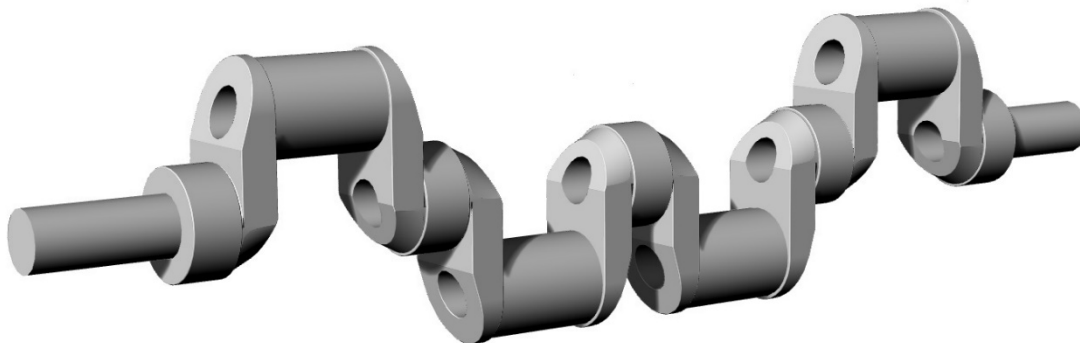

A major challenge was finding a suitable main bearing for the crankshaft.

The supports for the main bearings would accept a bearing with an external diameter of up to 20mm, but the minimum internal diameter was somewhat trickier. Since the bearings pass over the lands of the crankshaft, their internal diameter has to be larger than the crankshaft diameter under each bearing. On prototypes, the gap was made up by two half-sleeves which were slotted into place between the crankshaft and the bearing. I decided to take a similar approach. The crankshaft diameter under the bearing was 9mm. So I chose a readily available, affordable bearing with an external diameter of 18mm, internal diameter of 12mm and width of 4mm. It looked like it would work well. The following renderings (left and right views) showed how the bearing will just fit over the lands:

Starting to move the bearing over a land:

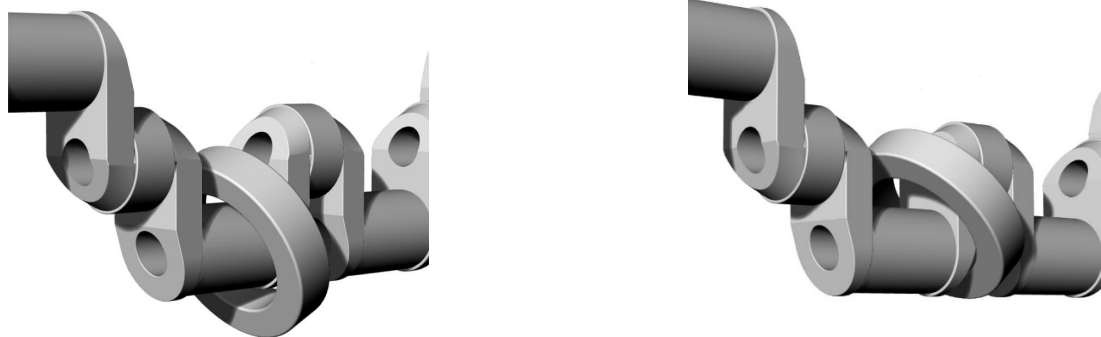



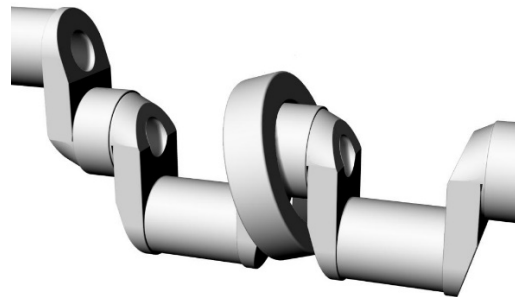
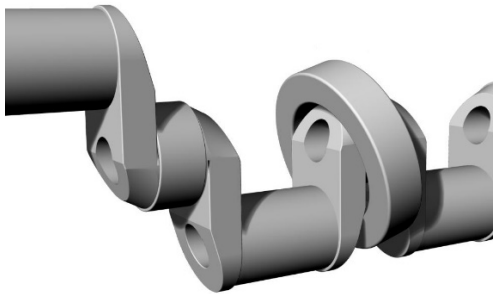
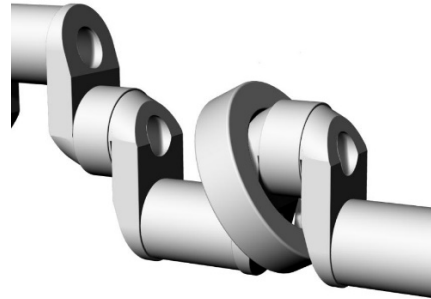
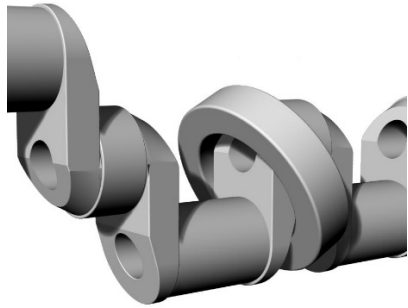
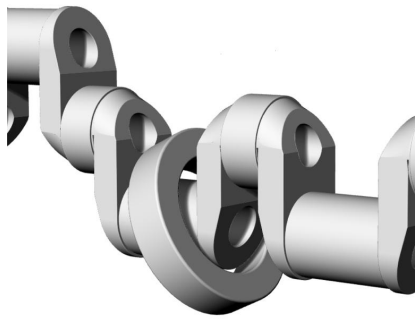

Here the bearing is in position. The half-sleeves still need to be added:

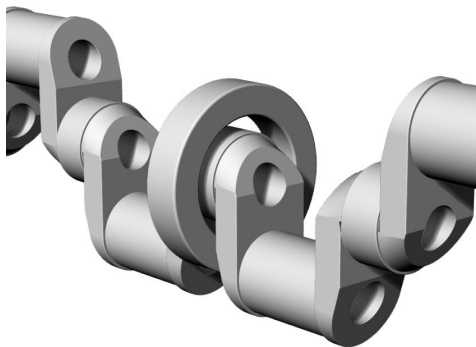

## Big Ends and Connecting Rods

Three connecting rods were connected to each of the four big ends. The central rod was part of the big end forging and the other two rods were hinged off each side. The big end was split in two so it could be installed around the crankshaft. It was secured in place by four bolts.

On the left is the prototype big end and rods, on the right a rendering of the CAD drawings:



## Pistons

The pistons were relatively straightforward, although I did take some liberties with interior dimensions to give the parts more strength. The piston diameter is also 0.5mm smaller than the bore. Given variabilities in 3D printing this should allow the pistons to move freely in the cylinders but without too much slop. Nevertheless, I did make provision for three piston rings at the top and one at the bottom, consistent with Napier practice. The ring slots are round (0.4mm dia), not rectangular, so piston rings could be made from 26Ga or 28 Ga wire, if they are needed.



Here's a rendering of the complete crankshaft and piston arrangement:

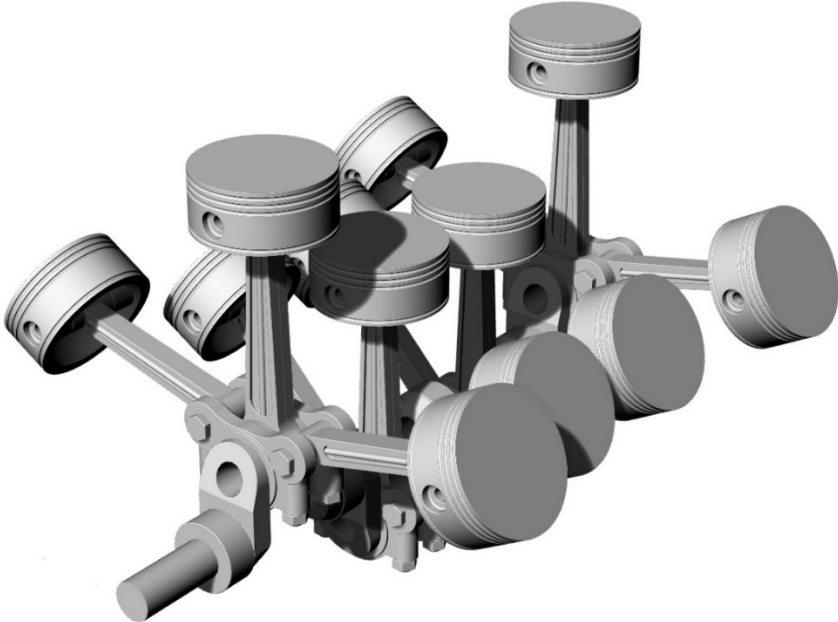

And here's a view of the underside of the engine with the sump removed:

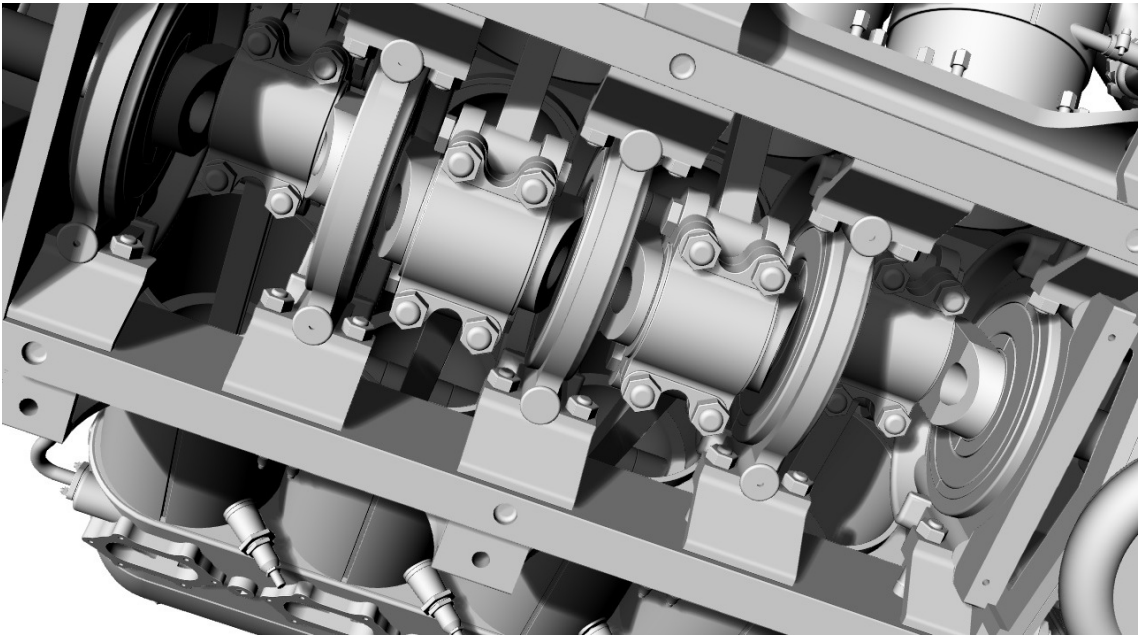

## Wheels & Tires

At this point, some of the parts for the engine were in the 3D printing process and others were taking a long time to make their way through the delivery system. So there was an opportunity to start thinking about the Napier-Railton chassis. One of the major challenges would be building the wire wheels and rubber molding appropriate tires. Those seemed like good things to be working on.

The Napier-Railton car used several different wheel and tire combinations. Currently the car is fitted with 21" dia rims and Blockley 6.75/7.00 x 21 crossply tires, so they seemed a good basis for the model. The recommended rim width is 4".

The wire wheels were a bit tricky, especially as there are many classic wire wheel lacing patterns. Nevertheless, based on several photographs, it was possible to figure out the arrangement of the spokes. On the outside were 28 spokes, and on the inside 56. The total of 84 is a significantly higher than most wheels of that era. But then the four wheels were carrying a vehicle weighing almost 3,500 lbs and designed for endurance racing at speeds of over 150 mph on a bumpy Brooklands track. Wheel strength was obviously very important.

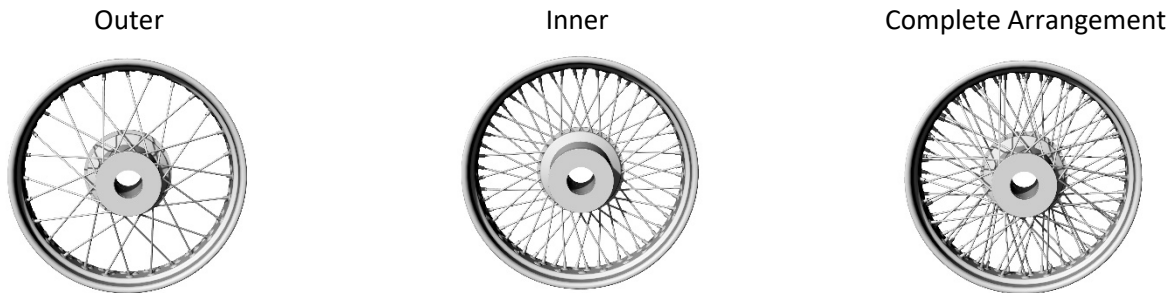

Helpfully, Blockley provides key dimensions for the tires:

Rim diameter	21"
Tread width	5.40"
Overall width	7.32"

Here are a couple of comparisons of the almost completed wheel and tire combination with the prototype:

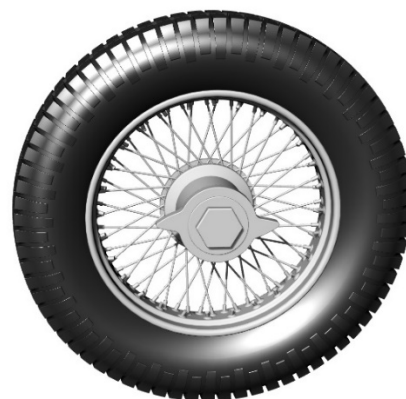



The spokes will be made from .020" (0.5mm) piano wire and the wire adjusters from short pieces of 1 mm thin wall brass tube. The 3D printed rims will have properly aligned holes for the spokes. The last major step will be molding the tires, but that will be the same process I used for the Austin Seven and Citroen Traction Avant tires.

This is the wheel and the tire with appropriate logos:



## Chassis

With the engine and wheel designs completed and 3D parts only coming in slowly, there was time to begin drafting the chassis and, maybe, the front and rear suspensions.

The biggest challenge was trying to figure out the engine position and mounting. As best as I could tell, based on all available photographs, the prototype chassis rails were 10" high (31.75mm in 1:8 scale) and 2" wide (6mm). They were spaced approximately 30" apart which is much wider than the 17" spacing of the mounting rails that were built into the Napier Lion engine. Clearly some kind of sub-chassis was used to support the engine although, at this point, I didn't know what it was. Nevertheless, based on photos, I was still able to guesstimate the engine height reasonably well. For example, the inlet to the muffler for the center bank of cylinders is above the exhaust manifold. And the position, and size, of the muffler could be calculated pretty well from profile photos of the prototype. That set one constraint. Another constraint was set because very little of the engine can be seen below the bottom of the chassis rails. Finally, the mufflers for the left and right banks lie alongside the chassis rails, but they need to be low enough that the outlet piping can pass below the lower forward spring mounting. The piping back to their exhaust manifolds created another constraint.

## Rear Suspension

The rear suspension was another challenge. The front part was relatively straightforward based on the several photos I had. The rear part was trickier but, for now what I've drawn seems to make sense. I'm hoping a future visit to Brooklands will fill in the details.

Below, are two renderings showing the engine, exhaust system and detail of the rear suspension all mounted on the chassis rails. The positions of the wheels were known from the published dimensions of the wheelbase (10' 10") and track (5' 3"):

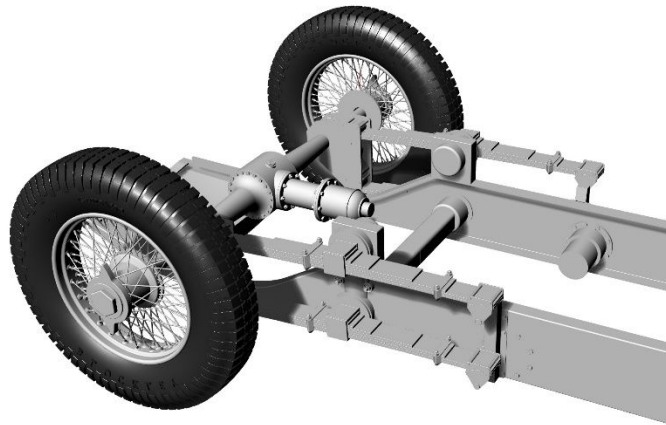
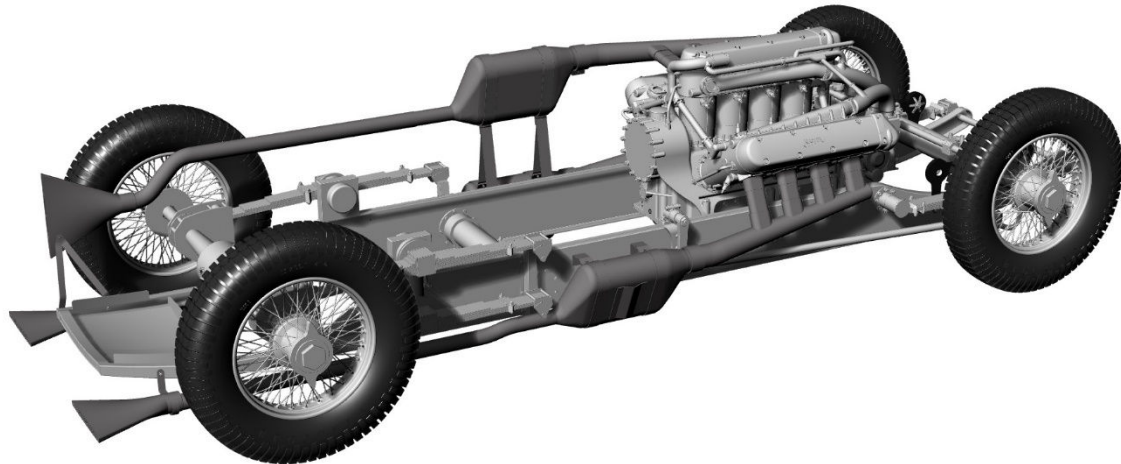

You can see that the chassis was underslung, which helped create a low center of gravity. Metal straps held the mufflers to the chassis rails and supported the center exhaust muffler. Note the stiffening plates on the outside of the mufflers.

Here's a comparison of my drawings to an old photo of the chassis:

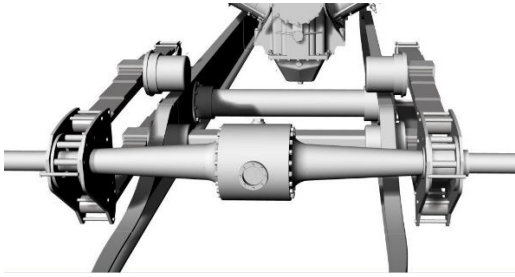

One interesting point. The photo above right shows disc brakes on the rear axle. However, the Napier-Railton was originally fitted with drum brakes, and only on the rear wheels. Since Cobb was trying to set speed records on straight or oval tracks, braking was secondary! The drum brakes are what I'll try to model. An additional driveline brake acted as a handbrake.

### Front Suspension

The front suspension consists of a solid front axle, leaf springs and adjustable Hartford friction plate shock absorbers in front of and behind the front axle.

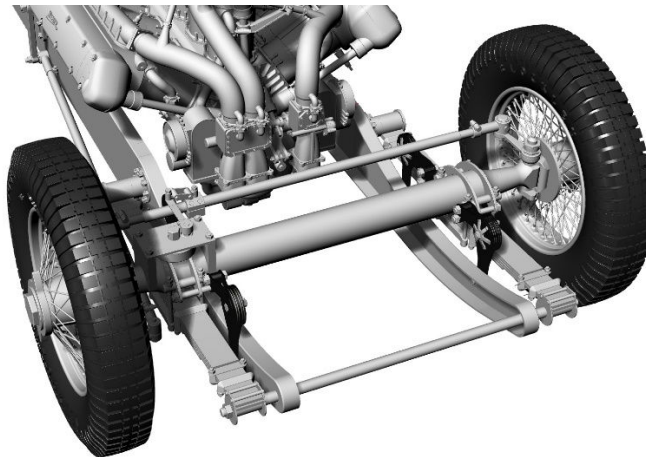

Because of the underslung chassis, the tie rod connecting the steering arms is located above the centerline of the front axle. Below is detail of the steering arrangement alongside the prototype:

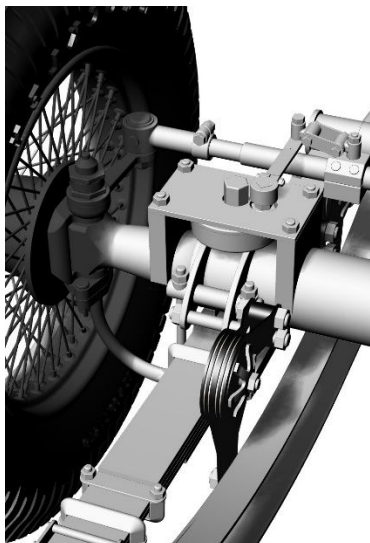

The horizontal circular drum, just above the axle appears to be part of a dampening mechanism for the steering. That would make sense since Brooklands was notorious for its very bumpy track.

## Steering Components

The next step was to add the steering arm, steering box, steering column and steering wheel. Here's a picture showing some of the detail of the steering arm in comparison to the prototype:

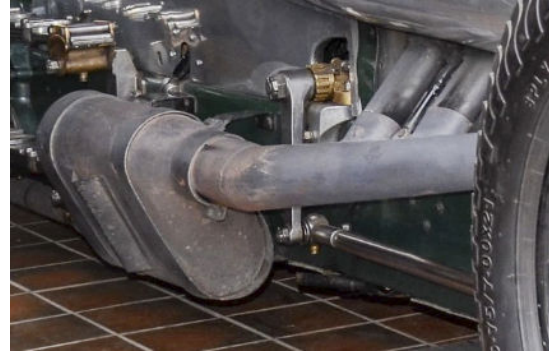
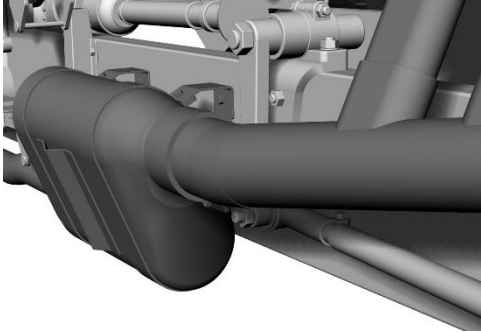

The steering wheel on the model will mirror the one on the current prototype.

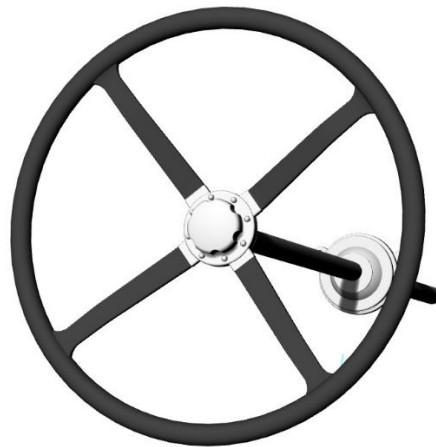

At this point, one unresolved question was the angle of the steering column with respect to the longitudinal axis of the car. Based on photographs and the position of the driver, it is clear that the outer edge of the steering wheel is inboard of the rear springs. This makes sense in the context of the body fairings needed to shroud the wheel and the driver's hands.

But the steering box is mounted just inside the chassis rail. This again makes sense; first, so the steering box doesn't interfere with the clutch housing and, second, so the steering box and steering arm are closely coupled. The logical outcome is that the axis of the steering column (and steering wheel), and also the orientation of the driver, are at an approximately  $7^\circ$  outward angle to the centerline of the chassis. It's somewhat unusual but I'm pretty sure a check of the prototype would confirm it.



The steering column is anchored in place by three struts, which attach to the chassis. They are clearly visible in the photo on the left. Holes in the bodywork accommodate the struts.

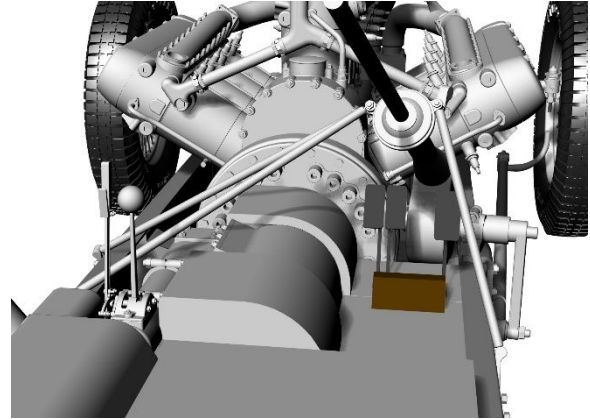

The gearbox and adjacent components were a significant challenge. Unfortunately, I could find very few relevant photographs of the gearbox and adjacent components. So, drawing them was particular challenge. Until I can make a visit to Brooklands, I've relied on the photographs I had, a little bit of guesswork and some engineering common sense to generate the drawings! Updates may be necessary! Still, the handbrake and gear shift arrangement look reasonable:

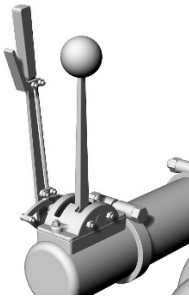

And this rendering gives a broader view::

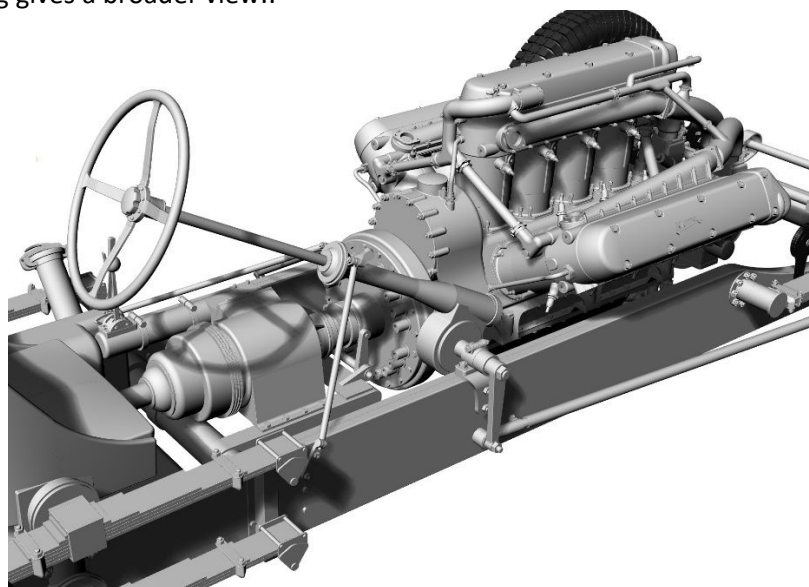

One interesting side note. The car had a 15 gall (Imp) oil tank. That's a lot of oil and needed a big tank. To get that capacity, the tank is both to the left off and also under the driver's seat.

One late item I added to the drawings was the 16" drum brakes. They were only fitted on the rear wheels since braking was not a big factor on the Brooklands track. There are no pictures of the original brake arrangement, but the following is a typical arrangement:

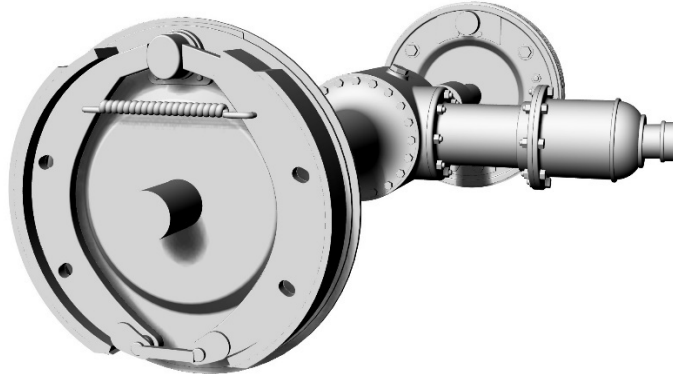

Subsequently, after the car was retired, and converted for use in testing parachutes, the drum brakes were replaced by disc brakes which are currently on the vehicle.

The side profile was now starting to look very similar to the side profile sketch of the prototype:

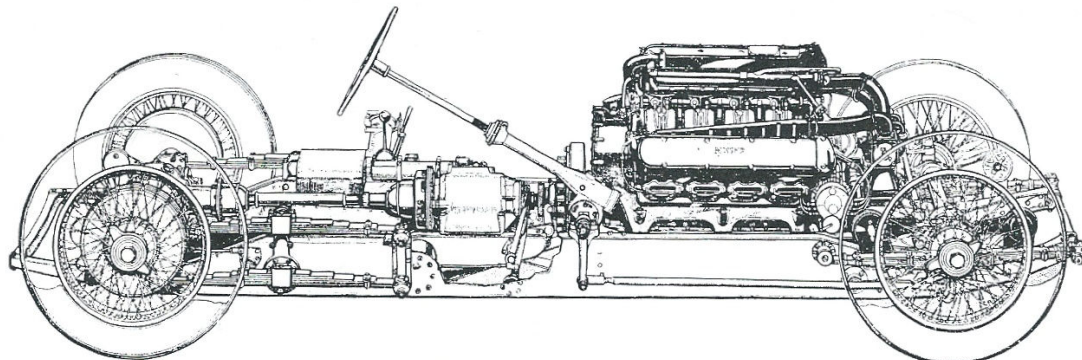
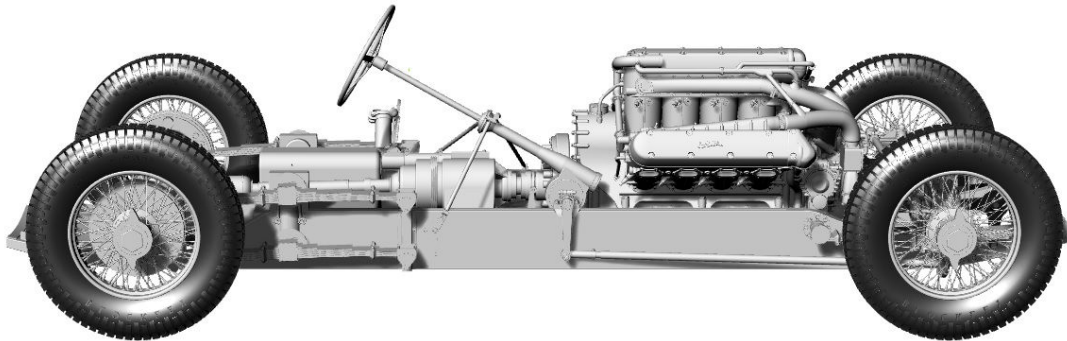

The bulk of the chassis drawings are now complete so, with engine parts now at hand, it seemed like a good time to shift gears and turn my attention to construction of the engine. Except .... a couple of nagging issues still remained. One was the radiator.

## Radiator

I wanted to include the radiator in the model, but the bulk of it was hidden by the radiator cowling and the front of the engine. What I knew was that there was a large 2" diameter pipe that flowed water from the front of the engine (i.e. nearest the cockpit) alongside the engine to the radiator. And there was a connection from the bottom of the radiator to the water pump. Obviously, the outer dimensions of the radiator were also constrained by the radiator cowling. So, if I drew the cowling, then the radiator dimensions and arrangement could be figured out!!

Here's the radiator, with and without it's cowling:

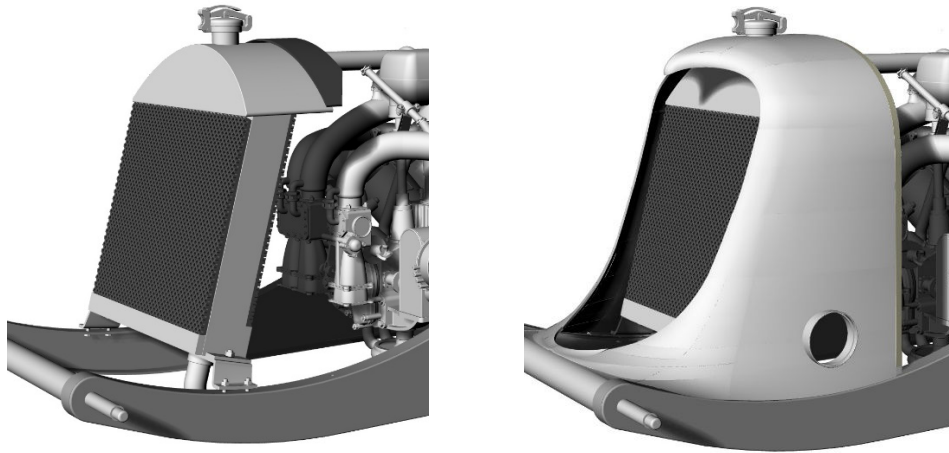

The grill is a 3D printable honeycomb of open squares and provides a realistic grill-like appearance. The mounting bracket, bolted to the chassis frame, works. But I have no idea if it's correct or not!

The cowling drawing required a few iterations in an effort to make the proportions (and the distinctive 'cow-lick') as realistic as possible. Gurney Nutting, one of the premier coachbuilders in the 1930s, designed the body and they obviously put some flare into the design!

## Bonnet & Side Panels

But now, with the radiator cowling complete, it made sense to try drawing the bonnet and the engine side coverings. Because I wanted a 3D printable version of the bonnet, the big challenge was going to be the louvers. Fortunately, I had figured out a way to do something similar on another model. So, after a dive into the memory bank, here's the left-hand side with its large opening for the center exhaust manifold:

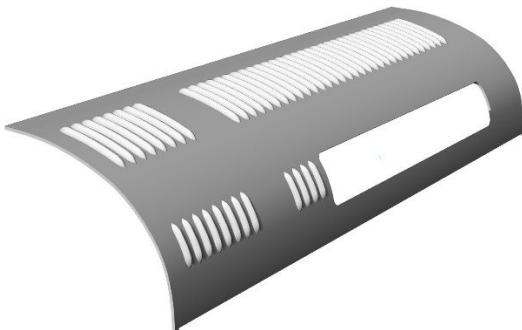

The louvers are slotted all the way through.

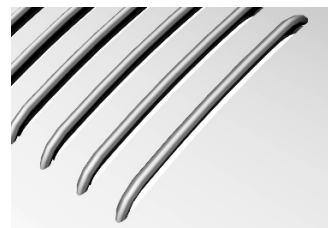

The side panels include fairings that cover the rocker covers. Miniature piano hinges, with a removal pin (just like the prototype), will link the bonnet tops and sides:

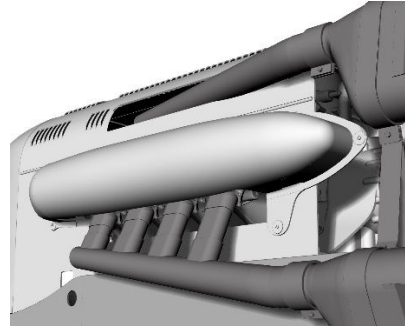
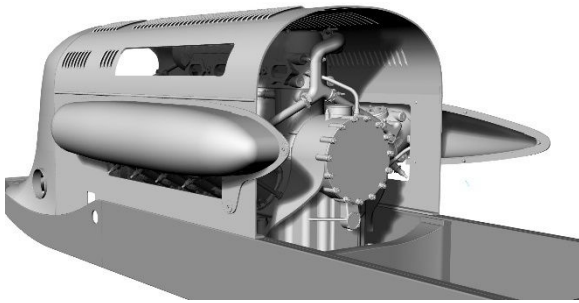

Because of the central exhaust pipe (on the left-hand side), the fairings aren't symmetrical.



On the prototype, bonnet straps held the bonnet tops in place. They will be included in the model to give it more realism. They will be fabricated rather than 3D printed, but here's a closeup of how they will look:

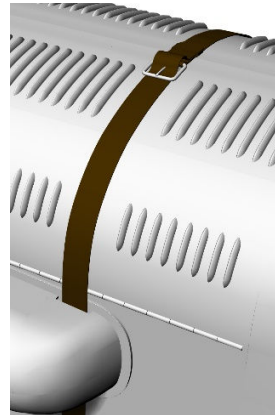

## Rest Of The Body

Having got this far it seemed logical to go ahead and finish drawing the body.

One area of uncertainty was the body flair around the steering wheel. There was a substantial flare around the seat, no doubt to accommodate the elbows of the driver. But on the current version of the prototype, the flare around the steering wheel is much less pronounced. However the famous picture of the Napier Railton 'leaping' at Brooklands, shows a substantial flare around the wheel. That made sense to me given the air pressures when traveling at over 150 mph. So that's what I chose to model.



Drawing the tail was relatively straightforward except for a couple of issues. First, I wanted to make sure that the tail would accommodate a fuel tank that had the requisite 65 gall (Imp) capacity. It wasn't really necessary ... who's going to see the tank and who's going to calculate the capacity? But 65 gall. is a lot of fuel so it was a fun distraction to see what was required. As you can imagine, the tank fills most of the tail. A full tank of fuel also weighs close to 500lb, and almost all of it is behind the back axle. That must have made for some interesting vehicle dynamics at speed! The second issue was the fairing behind the seat. It's a complicated shape and has a flange that was riveted to the tail. Since I was also wrestling with the exact location and size of the seat, it took a couple of iterations to get it to look right.

In any event, here's a side profile of the finished body panels. They can all be 3D printed.

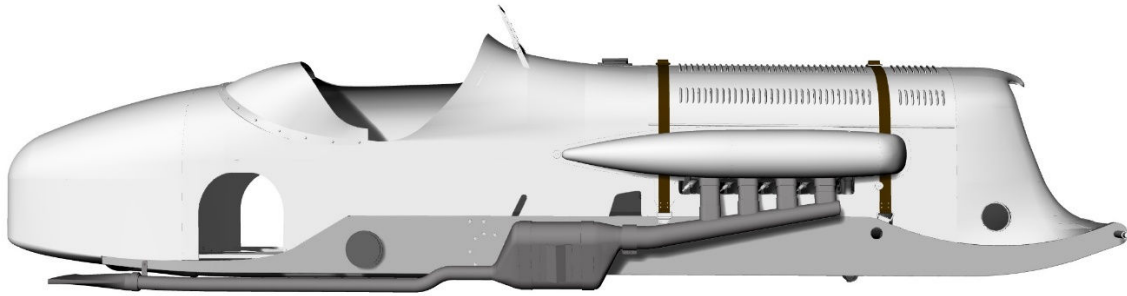

The cutouts you see are, from left to right, for the rear axle assembly, one of the steering column braces, the steering arm and, on the far right, the front axle.

## Dashboard

One of the last elements to add to the body, was the dashboard. Here's a comparison:



The decals aren't made yet, but there's enough detail in various photographs to create very close approximations.

The instruments have also been designed to be backlit by LEDs. But that will likely be a step too far for this model.

## Windshield & Rearview Mirror

As will be obvious from the above, there was a small windshield in front of the driver and a small, shrouded rearview mirror. Both will be fabricated, but they will be included in the drawings for completeness' sake.

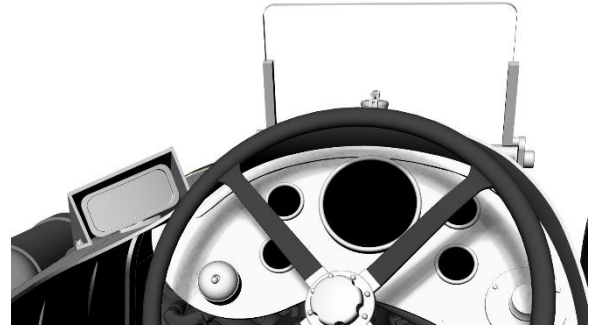

## Full Drawings

The drawings are now almost 100% complete.

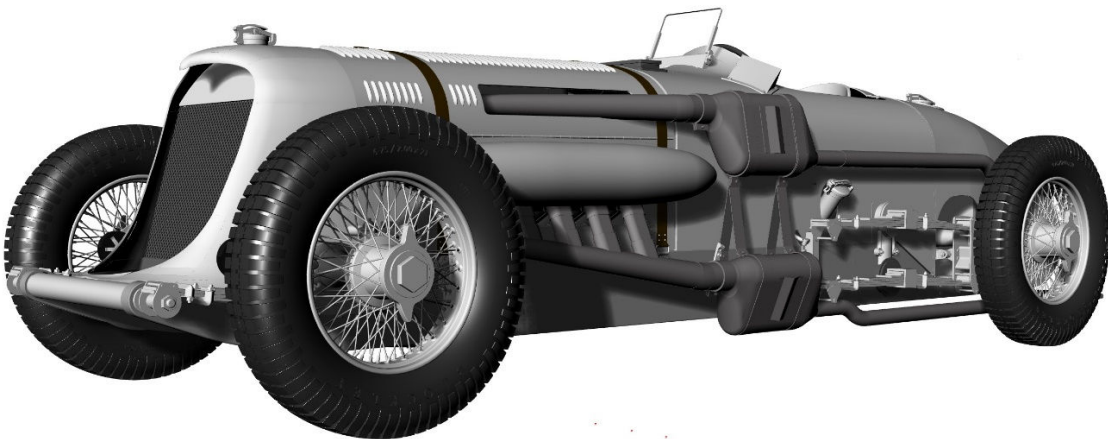
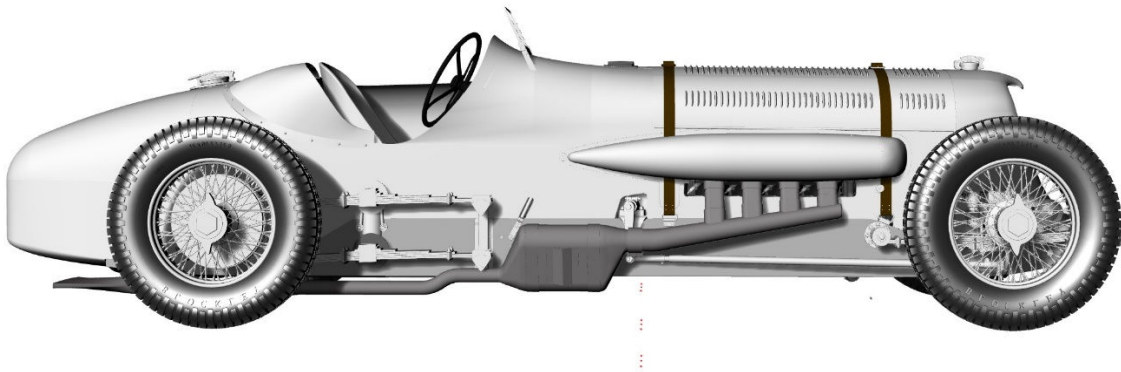

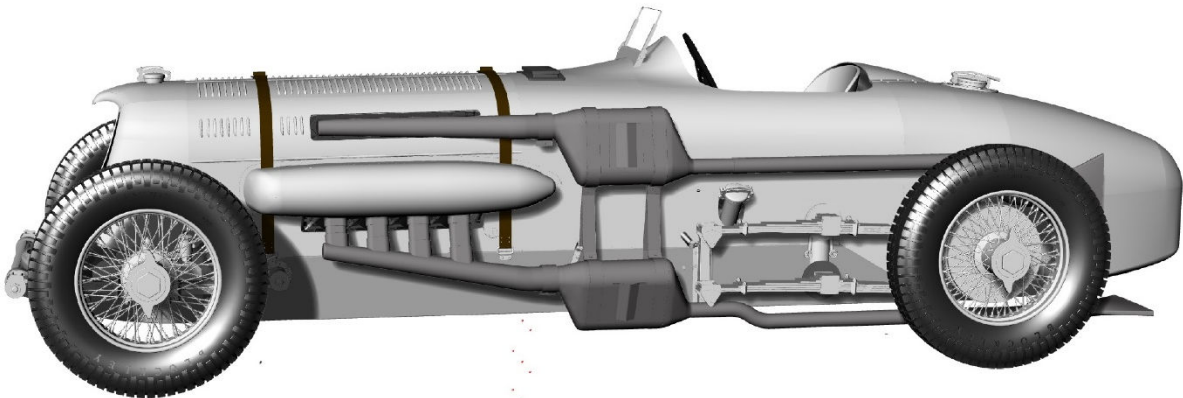
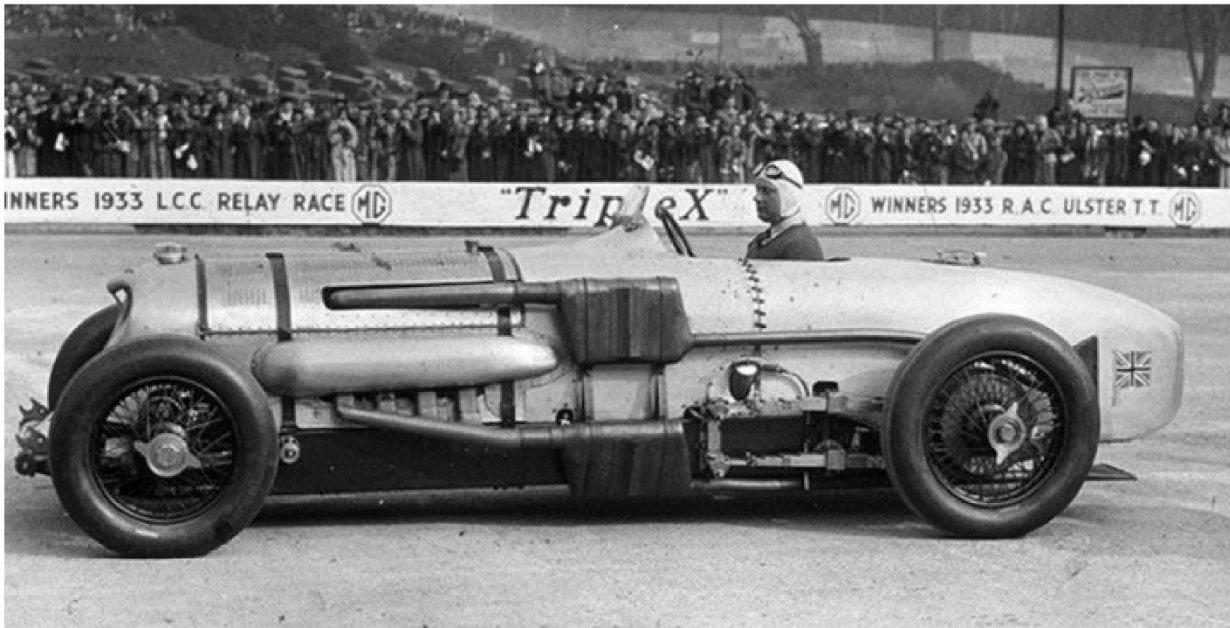
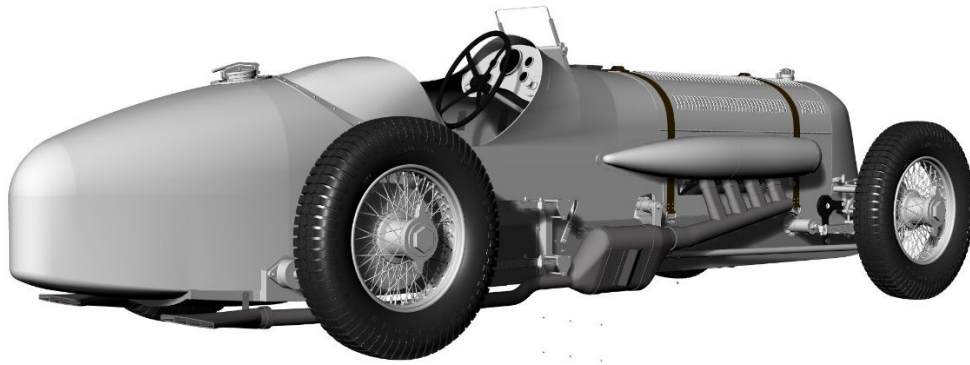

The body parts are now on order, so it really is time to start construction!!